

Installation Instructions

Electronic Mortise Lock E Series

HARDWOOD®

EPMLA01

1 Tools Required



Pencil



Hammer



Chisel

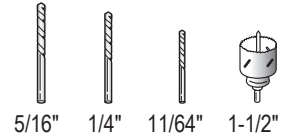

Drilling machine & heads

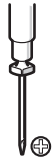

Phillips screwdriver



Tape measure

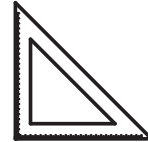

Combination square

2 Exploded View

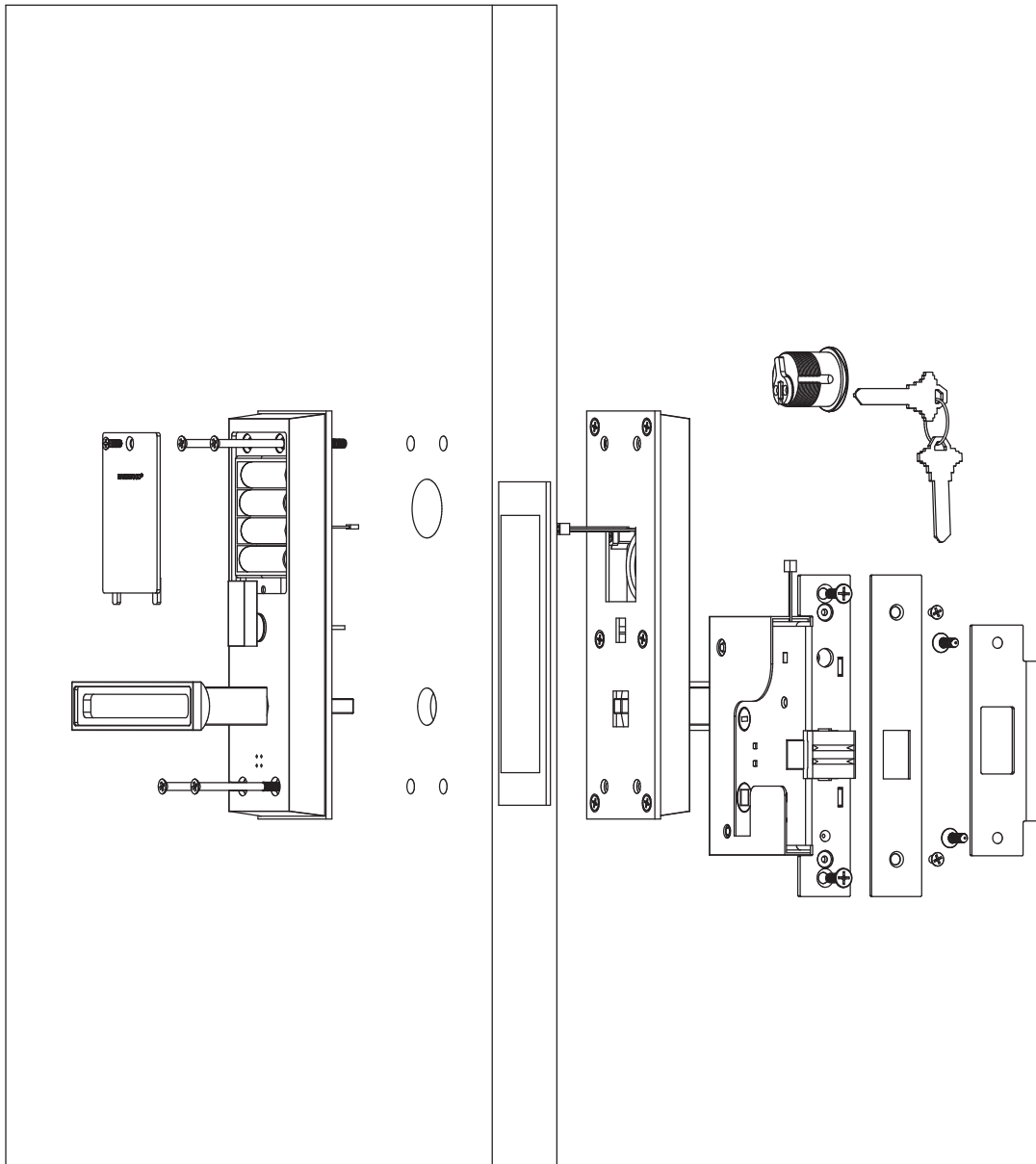

Outline dimensions: 220 x 70 x 75mm

EPMLA01

Installation Instructions

3 Installation

a Door Preparation

- Check the template to prep door for function holes, size & location.
- Clean out door pocket and door edge of any debris.

Note: Door thickness is required between 40mm ~ 50mm.

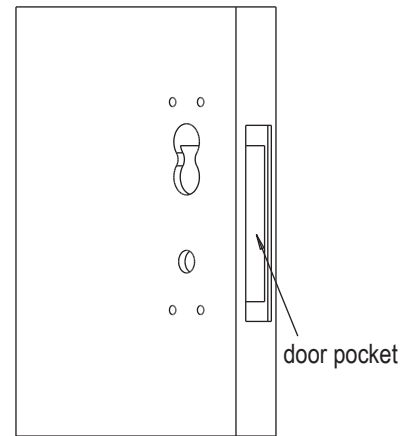

b Install Mortise Lock

- Make sure the handing of the lock (latch & locking piece) match the handing of the door. Slide lock into the door and fix it with 2 Phillips screws.
- Threading the wire through the hole to the outside of door.

Note: Keep door open while installing lock.

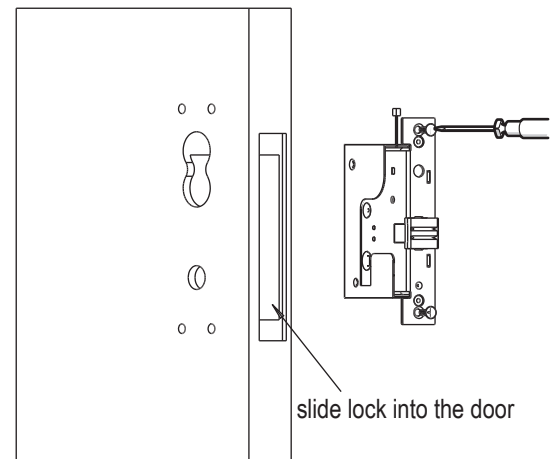

c Install Outside Escutcheon

- Slide spindle into the outside escutcheon.
- Connect the wires of escutcheon and lock.
- Insert spindle into square hole of mortise lock.
- Thread the other wire of outside eschtcheon through the hole to the inside of door.

Note: Verify the outside escutcheon before installing.
Make sure spindle with spring.

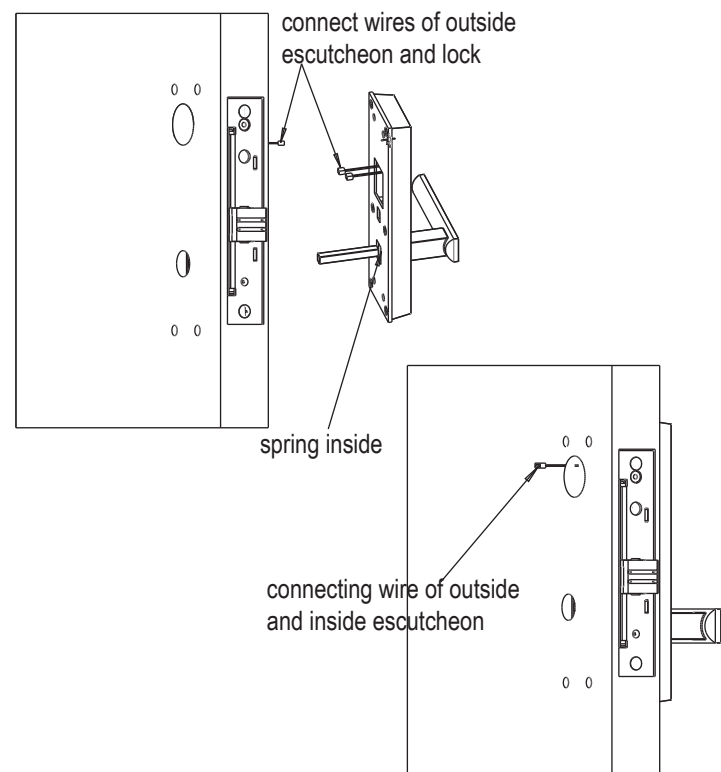

Installation Instructions

3 Installation (cont.)

d Install Cylinder

- Screw the cylinder in the lockbody lockwise until its face flush with the outside escutcheon.
- Secure cylinder with one Phillips screw.
- Make sure the latch can retract by operating cylinder while can't by operating outside lever.

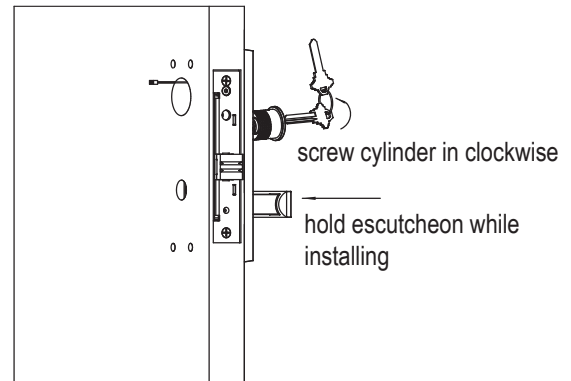

Note: The direction of keyhole is vertical. (See the image.)

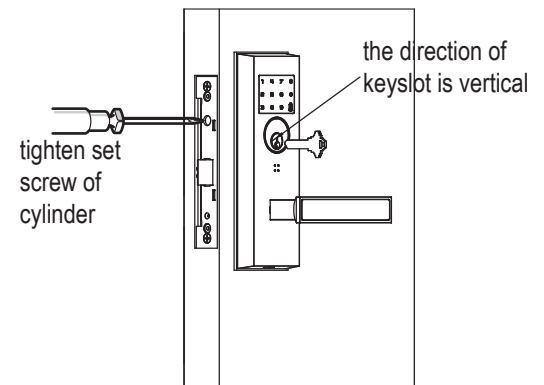

e Install Inside escutcheon

- Slide spindle (with spring inside) into the inside escutcheon.
- Connect wires of inside and outside escutcheon.
- Clear up the extra wire and put it into the through hole of door.
- Insert the spindle into the square hole of mortise lock and the tailpiece into the safty hole.
- Tighten 4 Phillips screws to fix inside and outside escutcheon.
- Check from inside of door. Make sure the thumbturn can lock the latch and the inside lever can retract the latch.

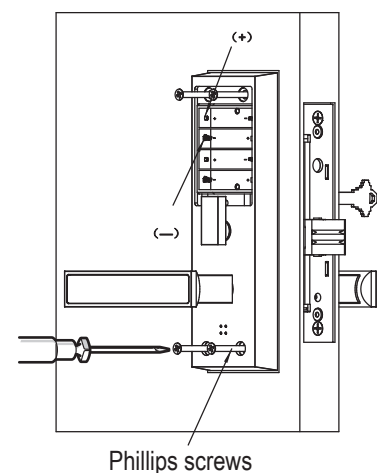
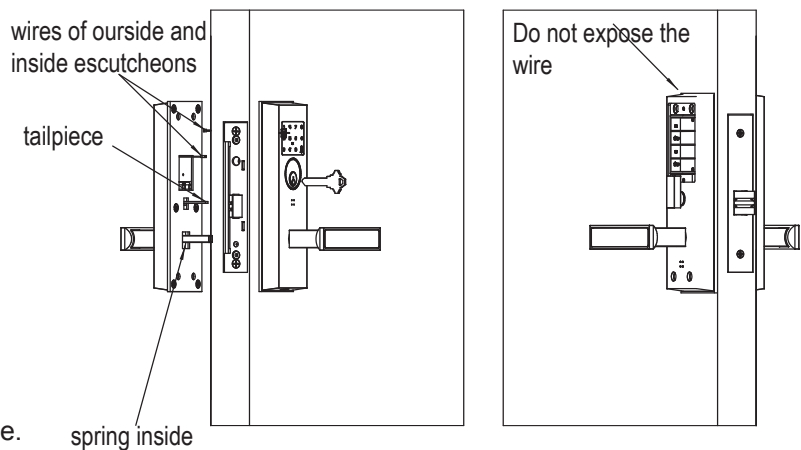

EPMLA01

Installation Instructions

3 Installation (cont.)

f Install Batteries

- Put 4 AA batteries into the battery box according to the indication of positive and negative.
- Close the battery cover, and fix it with 1 screw.

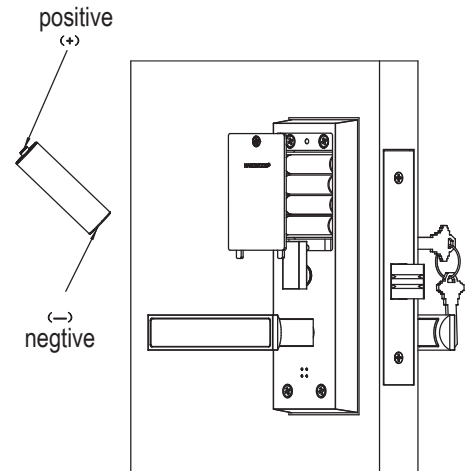

g Install Faceplate and Strike

- Secure faceplate of lock using 2 machine screws.
- Verify strike location according to template.
- Install the strike using 2 sheet metal screws.

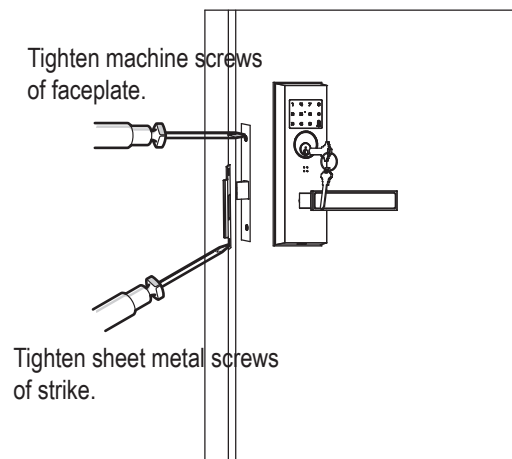

4 Trial Operation

After installation, check and make sure the lock is working properly.

- Set up password, IC card according to the enclosed operation instructions.
- Check all functions step by step.

Note: Keep door open when testing.

Keep the key for emergency when testing.

